

INSTALLATION INSTRUCTIONS



Item #651730 - 1/2 HP 115v
#652107 - 1/2 HP 230v
#652109 - 1 HP 230v

#652113 - 2 HP 230v
#652115 - 3 HP 230v
#652525 - 5 HP 230v



Table of Contents:

Important Information	2	1 - 5 HP 230v Contents & Installation.	10-15
1/2 HP 115v Contents & Installation.	3-4	1 - 5 HP 230v Wiring Diagrams	16-19
1/2 HP 115v Wiring Diagram	5	Timer Maintenance & Operation	20-21
1/2 HP 230v Contents & Installation	6-8	Warranty Information	22
1/2 HP 230v Wiring Diagram	9		

IMPORTANT INFORMATION:

Please read these instructions thoroughly before use. Failure to follow instructions may result in equipment damage or failure, losses, injury or death.

Electrical connections to the control panel and proper grounding (properly sized copper conductor from the grounding terminal to the service panel or grounding rod) are to be completed by a licensed electrician and in accordance with the National Electric Code, local codes or ordinances.

⚠ WARNING: ⚠

To reduce the risk of electric shock or injury:

- EXTERNAL MAIN DISCONNECT MUST BE PROVIDED
- This control panel contains a Ground Fault Circuit Interrupter (GFCI). DO NOT remove, bypass or modify the GFCI.
- DO NOT operate the control panel if electrical cords are broken or spliced.
- ALWAYS turn off electrical power before installing, removing or servicing the control panel components.
- DO NOT immerse the control panel in water.
- This control panel is NOT intended for use in swimming pools, swimming ponds, or other situations where bodily contact is made with the water. Although the control panel is designed for outdoor use, it should never be submerged in water.

⚠ CAUTION: ⚠

To reduce the risk of equipment damage or failure:

- The control panel is NOT submersible; do not place the timer where it might contact or fall into the water. Control panel must be installed a minimum of 300 mm / 12 in. above the electrical datum plane.
- DO NOT operate the control panel with a unit that exceeds the maximum voltage indicated by the control panel specifications. Operating with a unit larger than recommended can cause damage to the control panel and will NOT be covered under warranty.

IMPORTANT: Airmax is not responsible for equipment damage or failure, losses, injury or death resulting from failure to follow safety precautions, misuse or abuse of equipment.

TECHNICAL SPECIFICATIONS:

ITEM NUMBER	VOLTAGE	PANEL DIMENSIONS	MOUNTING DIMENSIONS
651730	1/2 HP 115v	9 1/2" w x 11 1/2" h x 4 1/2" d	6" w x 10 1/2" h
652107	1/2 HP 230v	16" w x 17 3/4" h x 8 1/2" d	12" w x 18 1/2" h
652109	1 HP 230v	16" w x 17 3/4" h x 8 1/2" d	12" w x 18 1/2" h
652113	2 HP 230v	16" w x 17 3/4" h x 8 1/2" d	12" w x 18 1/2" h
652115	3 HP 230v	16" w x 17 3/4" h x 8 1/2" d	12" w x 18 1/2" h
652525	5 HP 230v	16" w x 17 3/4" h x 8 1/2" d	12" w x 18 1/2" h

1/2 HP 115v PRODUCT CONTENTS:

Airmax 115v
Control Panel
1/2 HP

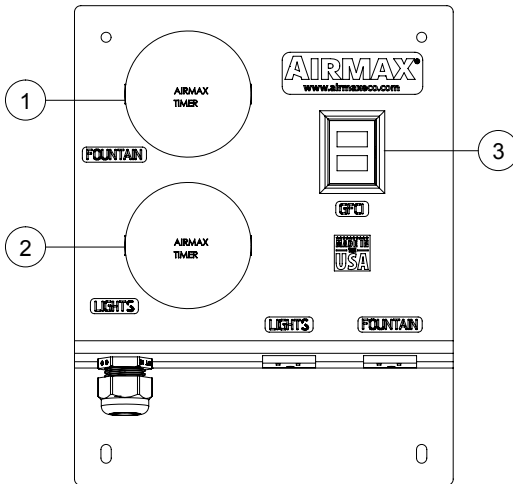

1/2 HP 115V REPLACEMENT PARTS:

ITEM	DESCRIPTION	PART #	ITEM	DESCRIPTION	PART #
1	Motor Timer	651112	3	Motor and Light GFCI	651952
2	Light Timer	651112			

1/2 HP 115v INSTALLATION INSTRUCTIONS:

Airmax Control Panels are designed for outdoor use but should be mounted above any high water levels. We recommend using grommets to protect and seal the electrical access points and to help keep the control panel clean.

CONNECTING ELECTRICAL WIRING:

CONNECT UNIT TO CONTROL PANEL

⚠ WARNING: ⚠

Turn off electrical power before connecting units to the control panel.



Connect to a Fountain:

- Plug fountain power cord into receptacle labeled **FOUNTAIN**

Connect to Fountain Lights (optional):

- Plug light set power cord into receptacle labeled **LIGHTS**

Connect Control panel to Power Source:

- Plug control panel power cord into the main power supply

1/2 HP 115v CONTROL PANEL WIRING SCHEMATIC:

- Main Disconnect Supplied and Installed by Licensed Electrician
- Input Hubs Must Comply With UL 514B
**Shall Be Provided By Installer*

120V
 FLA 15A
 MIN SERVICE
 15A
 14AWG
 COPPER
 60° C

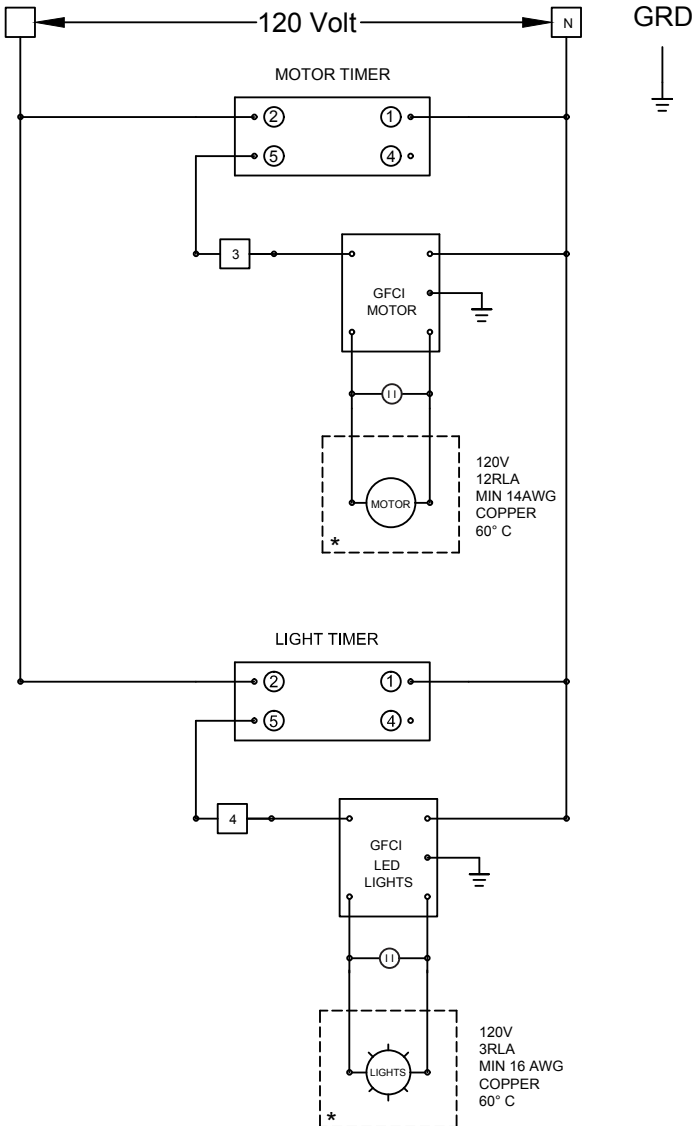

1/2 HP 230v PRODUCT CONTENTS:



Airmax 230v Control Panel 1/2 HP

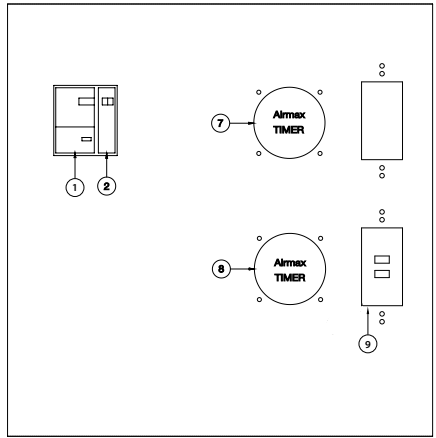
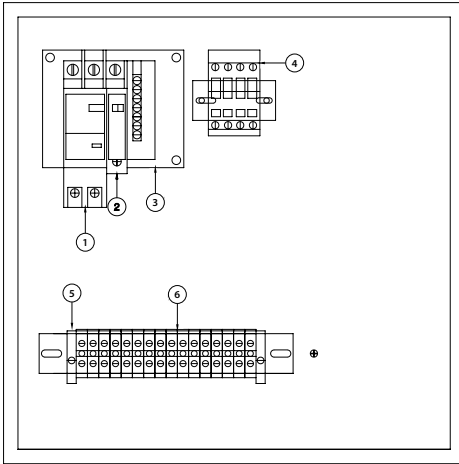

1/2 HP 230V REPLACEMENT PARTS:

ITEM	DESCRIPTION	PART #	ITEM	DESCRIPTION	PART #
1	Motor GFCI Breaker (15 Amp)	651971	6	Screw Clamp Feed-Through Kit (1each Grey Black White Red Green)	651781
2	Control Breaker (15 Amp)	651976	7	Motor Timer	651112
3	Breaker Base	651970	8	Light Timer	651112
4	1/2 HP Contactor 230v	651962	9	Light GFCI	651952
5	Screw Clamp End Barrier	651942			

1/2 HP 230v Field Wiring Diagram

NOTE: Incoming wire colors will vary by site

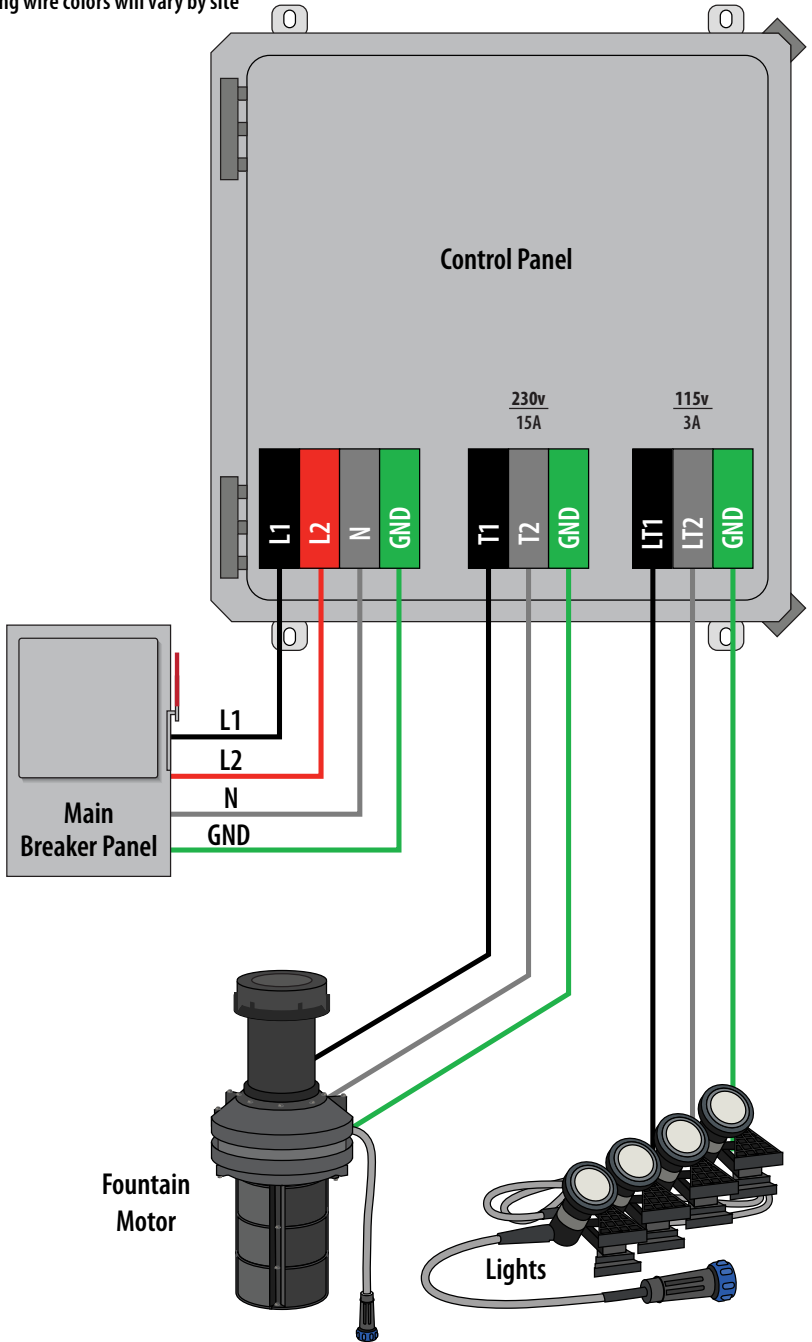

1/2 HP 230v INSTALLATION INSTRUCTIONS:

Airmax Control Panels are designed for outdoor use but should be mounted above any high water levels. Holes should be drilled into the bottom of the control panel for electrical access. We recommend using grommets to protect and seal the electrical access points and to help keep the control panel clean.

It is recommended that you have between 230 and 253 combined voltage on your incoming (L1 and L2) terminals. 208v power **IS NOT ACCEPTABLE** and will likely cause catastrophic failure to your power unit.

CONNECTING ELECTRICAL WIRING:

CONNECT UNIT TO CONTROL PANEL

⚠ WARNING: ⚠

Turn off electrical power before connecting units to the control panel.

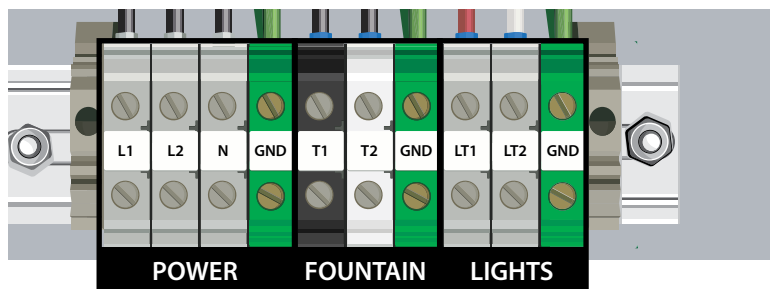

Connect to a Fountain:

- **Black** lead to the **T1** feed through
- **White** lead to the **T2** feed through
- **Green** lead to the **GND** feed through

Connect to Fountain Lights (optional):

- **Black** lead to the **LT1** feed through
- **White** lead to the **LT2** feed through
- **Green** lead to the **GND** feed through

CONNECT CONTROL PANEL TO POWER SOURCE

Connect the following:

- **Line 1** to the **L1** feed through
- **Line 2** to the **L2** feed through
- **White** to the **N** feed through
- **Green** to the **GND** feed through

1/2 HP 230v CONTROL PANEL WIRING SCHEMATIC:

- Main Disconnect Supplied and Installed by Licensed Electrician
- Input Hubs Must Comply With UL 514B
**Shall Be Provided By Installer*

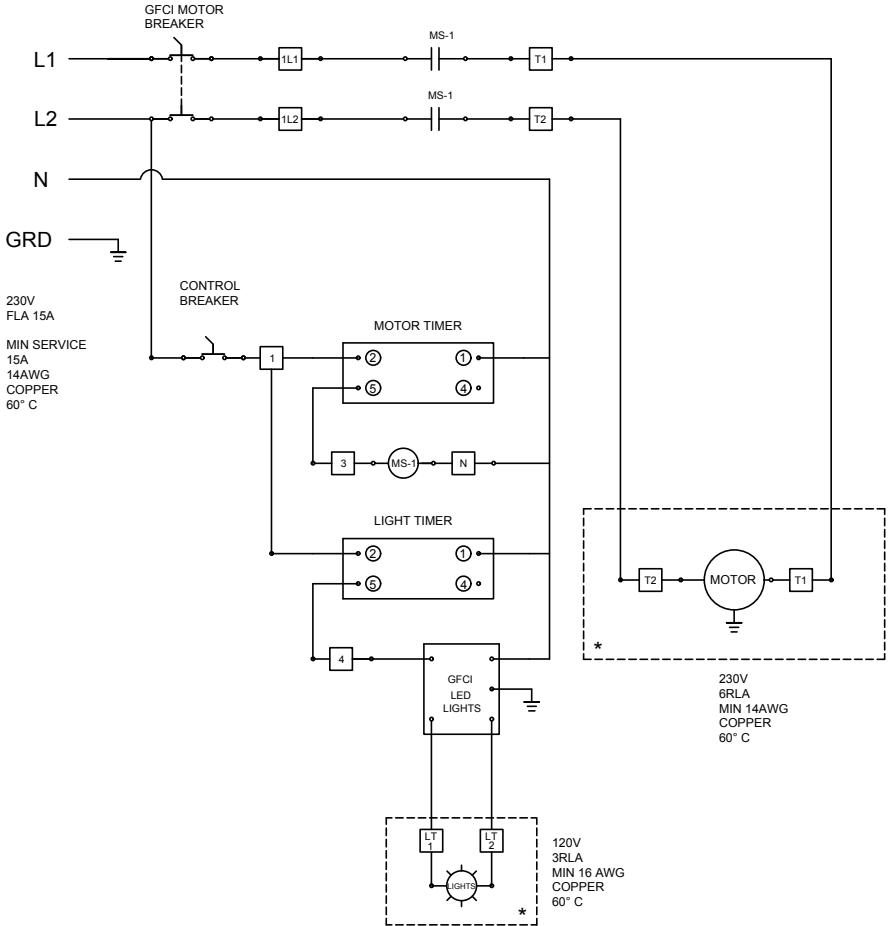

1 HP 230v PRODUCT CONTENTS:



Airmax 230v Control Panel 1 HP

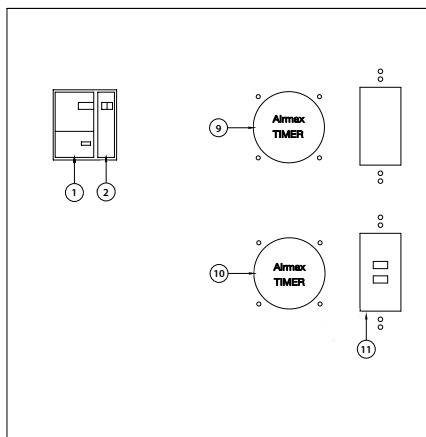
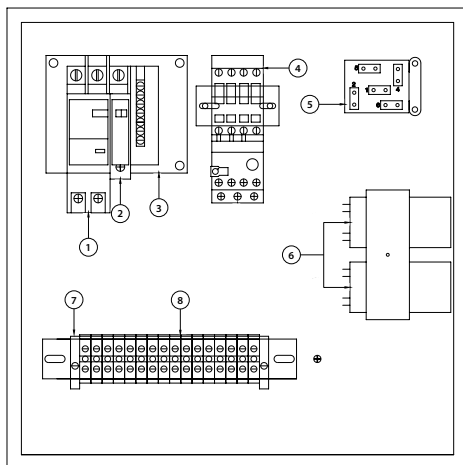

1 HP 230V REPLACEMENT PARTS:

ITEM	DESCRIPTION	PART #	ITEM	DESCRIPTION	PART #
1	Motor GFCI Breaker (20 Amp)	651068	7	Screw Clamp End Barrier	651942
2	Control Breaker (15 Amp)	651976	8	Screw Clamp Feed-Through Kit (1each Grey Black White Red Green)	651781
3	Breaker Base	651970	9	Motor Timer	651112
4	1 HP Contactor & Overload Repair Assembly	652313	10	Light Timer	651112
5	1 HP Potential Relay	652214	11	Light GFCI	651952
6	1 HP Capacitor Assembly (Start/Run)	654288			

2 HP 230v PRODUCT CONTENTS:



Airmax 230v Control Panel 2 HP

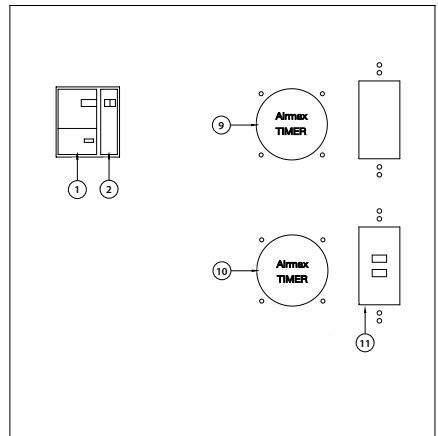
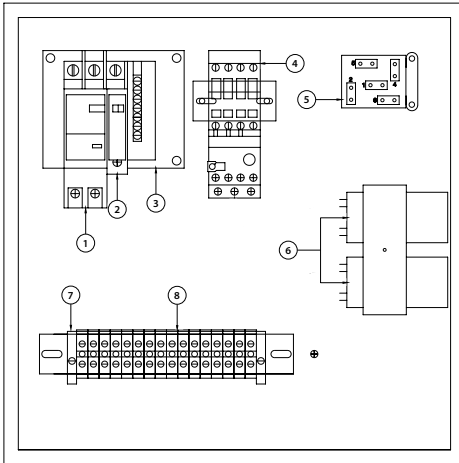

2 HP 230V REPLACEMENT PARTS:

ITEM	DESCRIPTION	PART #	ITEM	DESCRIPTION	PART #
1	Motor GFCI Breaker (20 Amp)	651068	7	Screw Clamp End Barrier	651942
2	Control Breaker (15 Amp)	651976	8	Screw Clamp Feed-Through Kit (1each Grey Black White Red Green)	651781
3	Breaker Base	651970	9	Motor Timer	651112
4	2 HP Contactor & Overload Repair Assembly	652314	10	Light Timer	651112
5	2-3 HP Potential Relay	652213	11	Light GFCI	651952
6	2 HP Capacitor Assembly (Start/Run)	654289			

3 HP 230v PRODUCT CONTENTS:



Airmax 230v Control Panel 3 HP

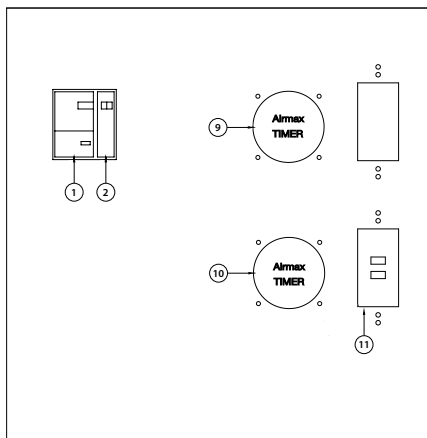
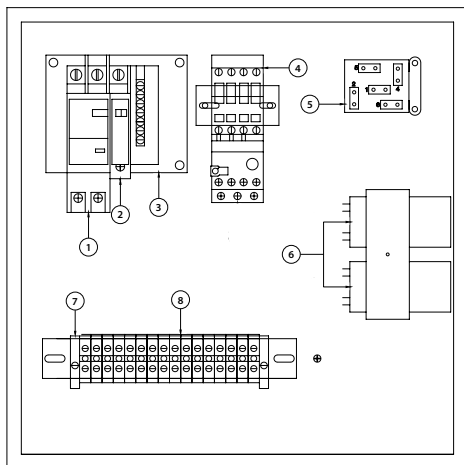

3 HP 230V REPLACEMENT PARTS:

ITEM	DESCRIPTION	PART #	ITEM	DESCRIPTION	PART #
1	Motor GFCI Breaker (30 Amp)	651882	7	Screw Clamp End Barrier	651942
2	Control Breaker (15 Amp)	651976	8	Screw Clamp Feed-Through Kit (Teach Grey Black White Red Green)	651781
3	Breaker Base	651970	9	Motor Timer	651112
4	3 HP Contactor & Overload Repair Assembly	653953	10	Light Timer	651112
5	2-3 HP Potential Relay	652213	11	Light GFCI	651952
6	3 HP Capacitor Assembly (Start/Run)	654290			

5 HP 230v PRODUCT CONTENTS:



Airmax 230v Control Panel 5 HP

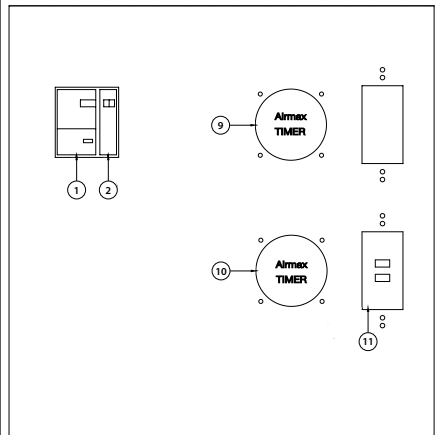
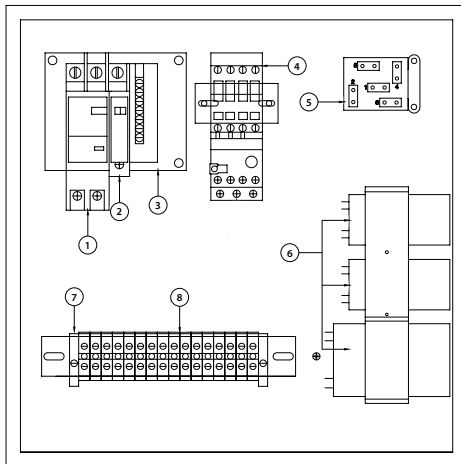

5 HP 230V REPLACEMENT PARTS:

ITEM	DESCRIPTION	PART #	ITEM	DESCRIPTION	PART #
1	Motor GFCI Breaker (40 Amp)	651975	7	Screw Clamp End Barrier	651942
2	Control Breaker (15 Amp)	651976	8	Screw Clamp Feed-Through (Gray)	652546
3	Breaker Base	651970	8	Screw Clamp Feed-Through (Green)	652547
4	5 HP Contactor & Overload Repair Assembly	653954	9	Motor Timer	651112
5	5 HP Potential Relay	652220	10	Light Timer	651112
6	5 HP Capacitor Assembly (Start/Run)	654291	11	Light GFCI	651952

1-5 HP 230v Field Wiring Diagram:

NOTE: Incoming wire colors will vary by site

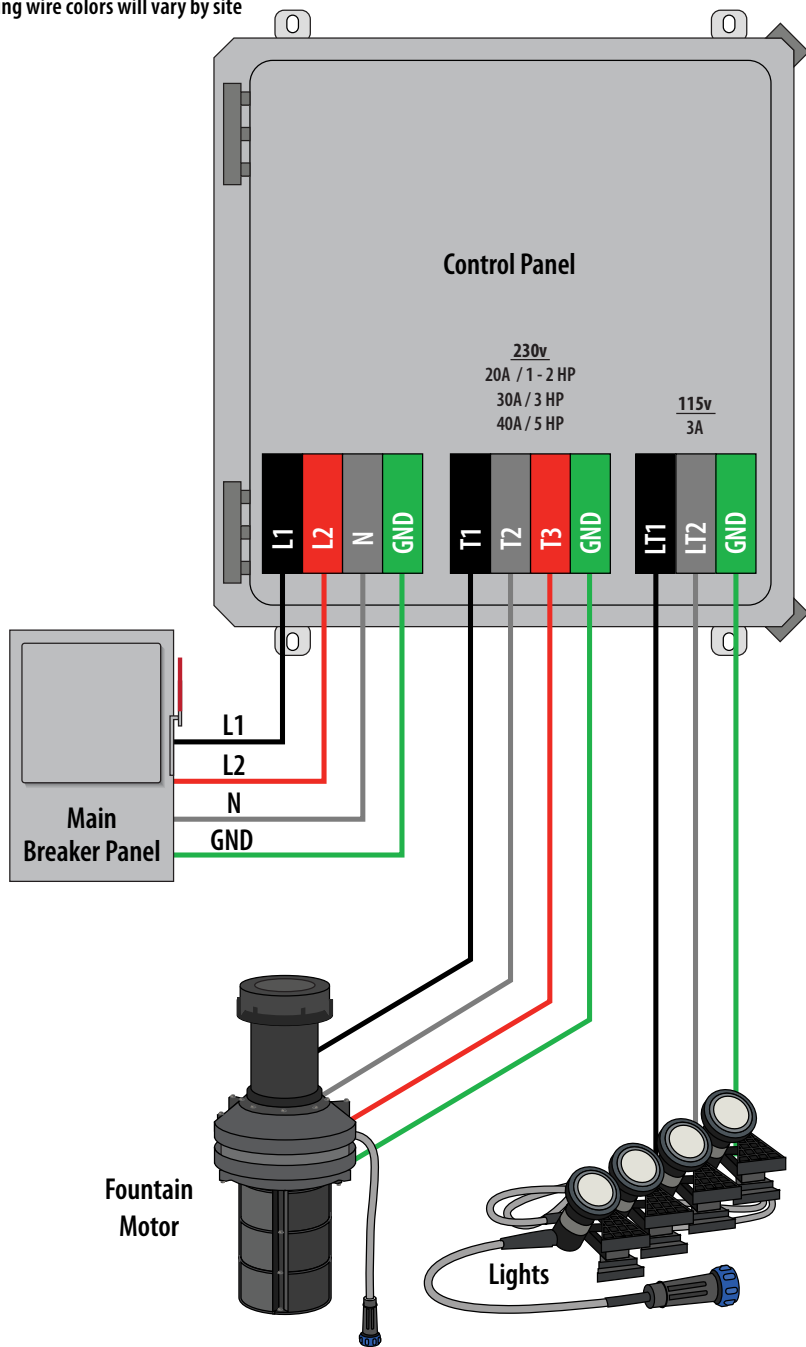

1 HP, 2 HP, 3 HP & 5 HP 230v INSTALLATION INSTRUCTIONS:

Airmax Control Panels are designed for outdoor use but should be mounted above any high water levels. Holes should be drilled into the bottom of the control panel for electrical access. We recommend using grommets to protect and seal the electrical access points and to help keep the control panel clean.

It is recommended that you have between 230 and 253 combined voltage on your incoming (L1 and L2) terminals. 208v power **IS NOT ACCEPTABLE** and will likely cause catastrophic failure to your power unit.

CONNECTING ELECTRICAL WIRING:

CONNECT UNIT TO CONTROL PANEL

⚠ WARNING: ⚠

Turn off electrical power before connecting units to the control panel.

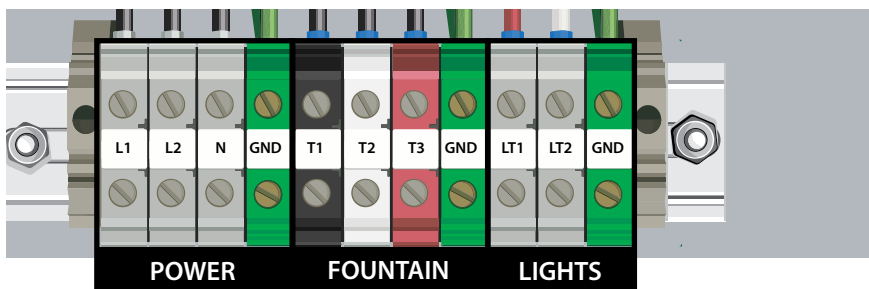

Connect to a Fountain:

- **Black** lead to the **T1** feed through (5 HP (gray) not shown)
- **White** lead to the **T2** feed through (5 HP (gray) not shown)
- **Red** lead to the **T3** feed through (5 HP (gray) not shown)
- **Green** lead to the **GND** feed through

Connect to Fountain Lights (optional):

- **Black** lead to the **LT1** feed through
- **White** lead to **LT2** feed through
- **Green** lead to the **GND** feed through

CONNECT CONTROL PANEL TO POWER SOURCE

Connect the following:

- **Line 1** to the **L1** feed through
- **Line 2** to the **L2** feed through
- **White** to the **N** feed through
- **Green** lead to the **GND** feed through

1 HP 230v CONTROL PANEL WIRING SCHEMATIC:

- Main Disconnect Supplied and Installed by Licensed Electrician
- Input Hubs Must Comply With UL 514B
*Shall Be Provided By Installer

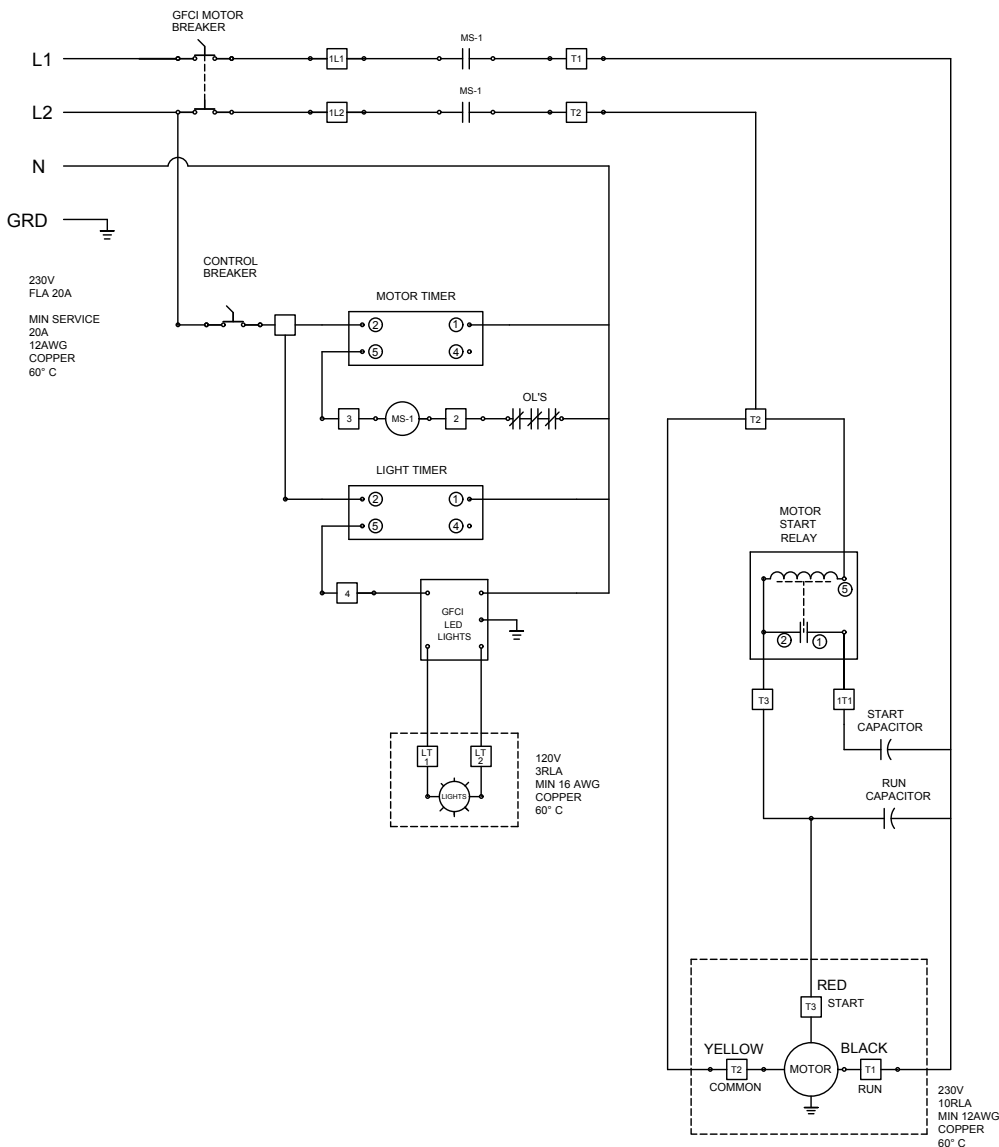

2 HP 230v CONTROL PANEL WIRING SCHEMATIC:

- Main Disconnect Supplied and Installed by Licensed Electrician
- Input Hubs Must Comply With UL 514B
**Shall Be Provided By Installer*

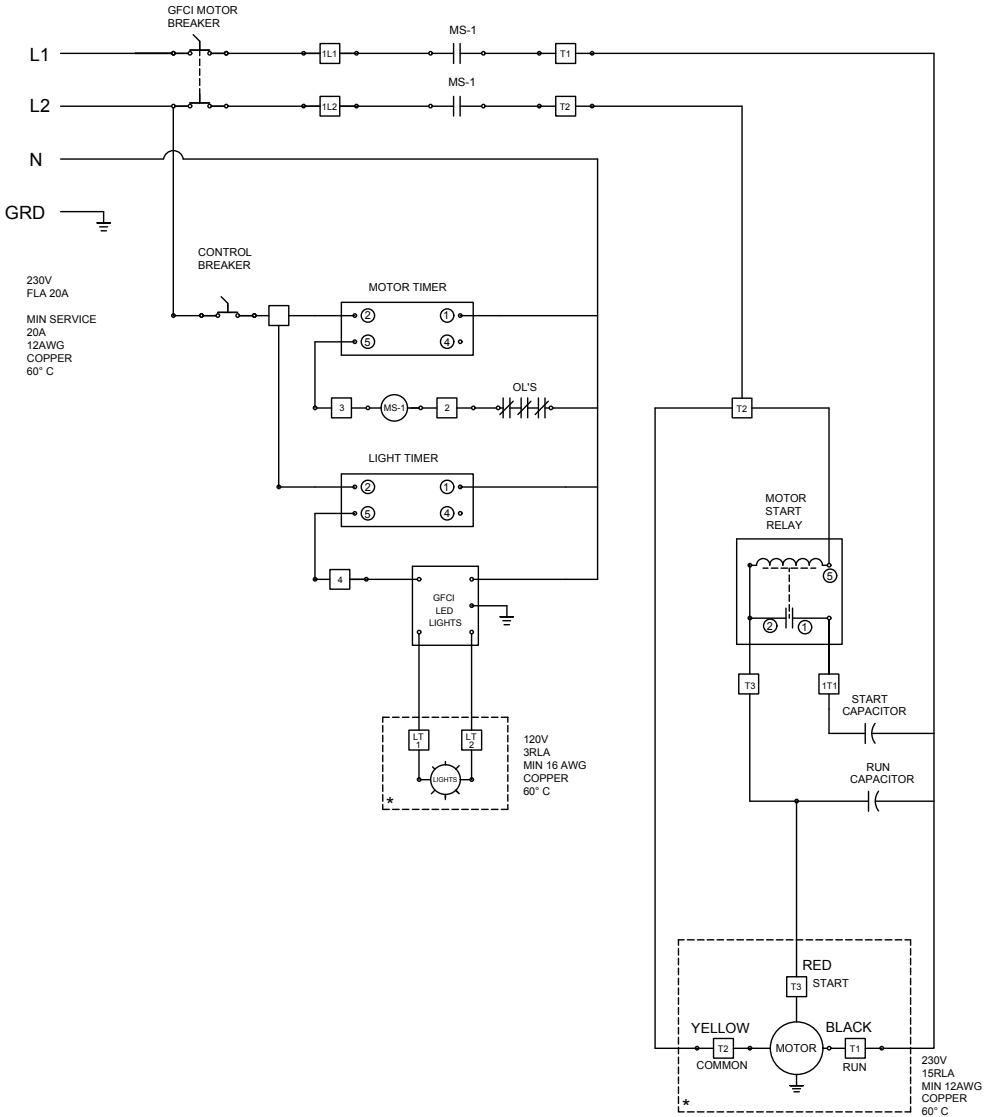

3 HP 230v CONTROL PANEL WIRING SCHEMATIC:

- Main Disconnect Supplied and Installed by Licensed Electrician
- Input Hubs Must Comply With UL 514B
**Shall Be Provided By Installer*

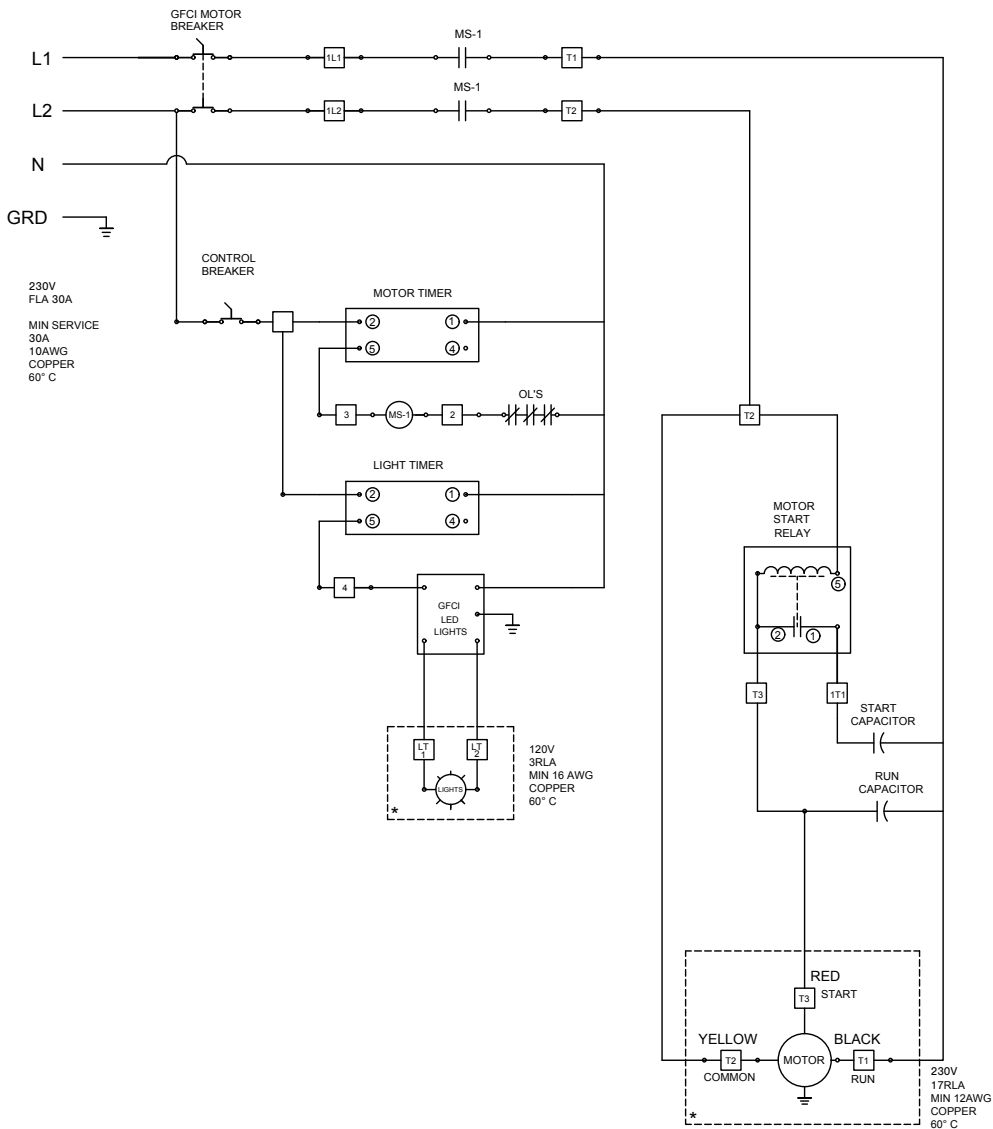

5 HP 230v CONTROL PANEL WIRING SCHEMATIC:

- Main Disconnect Supplied and Installed by Licensed Electrician
- Input Hubs Must Comply With UL 514B
**Shall Be Provided By Installer*

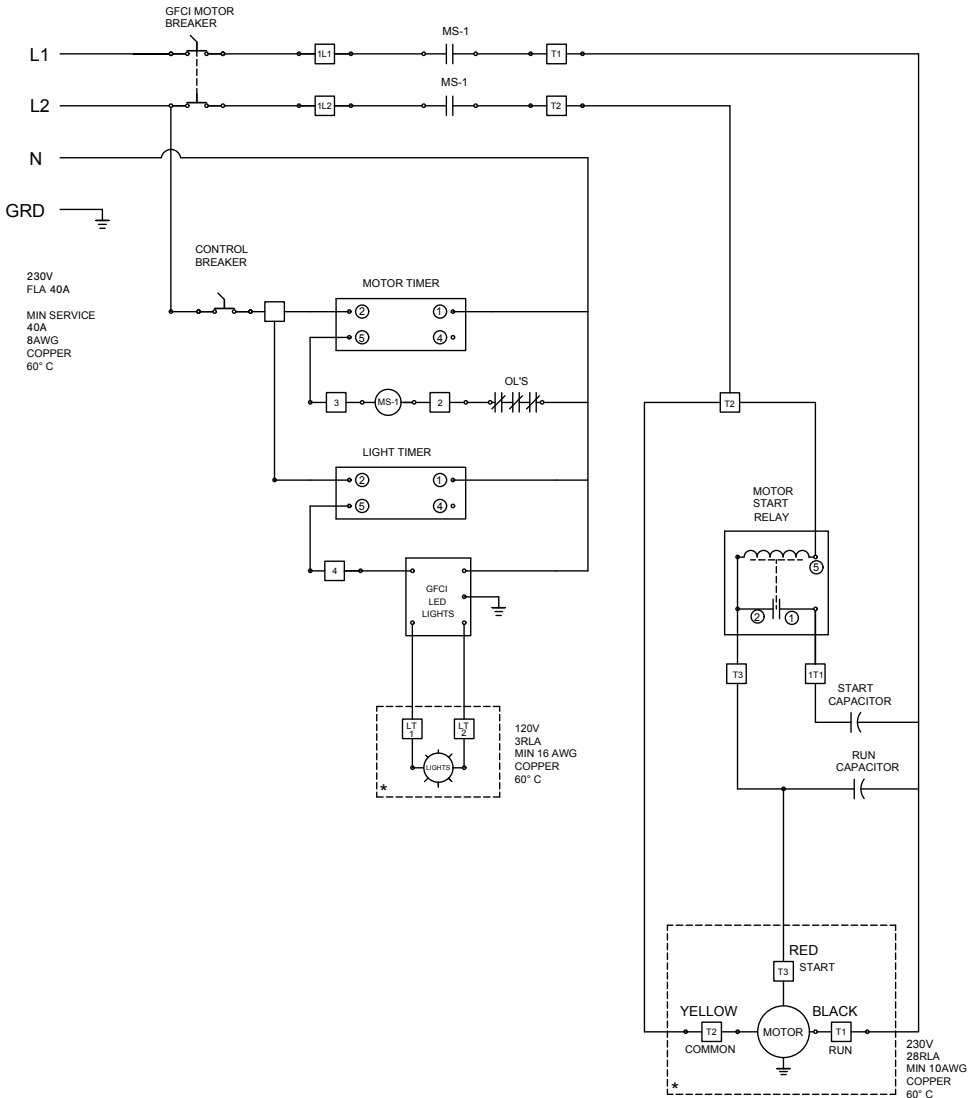

Maintenance & Operation of the Control Panel Timer:

RUN TIME USING THE MANUAL BYPASS

Press the MANUAL button until the line is above "ON". This mode will bypass all programmed settings. The MANUAL/ON mode can be used if 24/7 operation is desired.

RUN TIME USING A PROGRAM

Setting the Clock

- Step 1:** Press the RESET button to clear all history from memory.
- Step 2:** Press and hold the CLOCK button.
- Step 3:** Continue to hold the CLOCK button while pressing the DAY, HOUR or MIN button to set the day and time.
- Step 4:** Release the CLOCK button.



CREATING A PROGRAM

The Airmax Digital Timer allows up to allows up to 16 ON/OFF run times.

Select the days for each run time to occur based on the 15 preset schedule of days shown in the table. (Fig. 1 - on the next page)

Note: Ponds will receive the most benefit from continual water movement. We recommend running fountains at least 8-10 hours daily to maximize benefits, unless a secondary aeration system is in operation.

- Step 1:** Press the TIMER button once to display "1 on --:--"
- Step 2:** Press the DAY button to scroll through the preset schedule options. *Mode A, MONDAY - SUNDAY, is the default schedule.*
- Step 3:** When the desired schedule is displayed, press the HOUR or MIN buttons to select the ON time.
- Step 4:** Press the TIMER button once to switch display to "1 off --:--" Programming without inserting an OFF time will also allow the fountain to run 24/7 if desired.
- Step 5:** Press the DAY button to scroll to the program selected in step 2.
- Step 6:** Press the HOUR or MIN button to select the OFF time.
- Step 7:** Repeat steps 1-6 for each additional program desired, up to 16 programs.
- Step 8:** When all programs have been created press the CLOCK button to execute the programs.
- Step 9:** Press the MANUAL button until the line is above AUTO.

Maintenance & Operation of the Control Panel Timer Cont.:

		DAYS FOUNTAIN IS RUNNING							
PRESET MODES	a.	MO	TU	WE	TH	FR	SA	SU	
	b.	MO							
	c.		TU						
	d.			WE					
	e.				TH				
	f.					FR			
	g.						SA		
	h.							SU	
	i.	MO	TU	WE	TH	FR			
	j.						SA	SU	
	k.	MO	TU	WE	TH	FR	SA		
	l.	MO	TU	WE					
	m.				TH	FR	SA		
	n.	MO		WE		FR			
	o.		TU		TH		SA		

Fig. 1

EDITING A PROGRAM

Review a Program – To review the list of current programs, press the TIMER button repeatedly to scroll through the programs. When finished press the CLOCK button to return to the time of day.

Change an On/Off Time – To adjust an On/Off time, press the TIMER button to scroll to the program you want to change. Press the DAY, HOUR or MIN buttons to adjust the time. When finished press the CLOCK button to return to the time of day.

Add a Program – If there are not already 16 programs running, you may elect to add an additional program by following the CREATING A PROGRAM procedure.

Remove a Program – In the event that a program needs to be removed, you will need to RESET the timer and program only the desired schedules.

REPLACING THE BATTERY

Note: Timer settings will be retained for approximately 1 minute once the battery is removed. Each timer uses (1) CR2032 Lithium Battery.

Step 1: On the back of the timer, use a small flathead screwdriver or similar tool to pull the battery compartment from the timer.

Step 2: Install a new battery (print side down) and and reinstall the battery compartment.



WARRANTY:

Airmax Control Panels are covered under the system warranty
(3 Years - EcoSeries & PondSeries / 5 Years - LakeSeries)

THANK YOU FOR CHOOSING:

Airmax, Inc.

15425 Chets Way Street, Armada, MI 48005
866-424-7629 | www.airmaxeco.com | contactus@airmaxeco.com

#652090 V9